

HYDROTECH

Discfilter

17/21/31-series

 **VEOLIA**
WATER

Solutions & Technologies

Discfilter 17/21/31-series

Typical applications:

- ▶ Intake water
- ▶ Effluent polishing
- ▶ Aqua culture systems
- ▶ Industrial process water



Picture show Hydrotech Discfilters in municipal wastewater treatment plants for effluent polishing. The Hydrotech Discfilter is also used for filtration of intake water to municipal and industrial water supply systems, process water and effluent from pulp and paper industries, food industries, aqua cultures systems and many other applications.

- ▶ **Flow capacity:** Up to 1000 l/s per filter.
- ▶ **Filter opening:** 10-100 µm.
- ▶ **Filter media is easy to change** thanks to new innovative design.
- ▶ **Moving backwash system** for better cleaning, minimal water use and less wear on filter media.
- ▶ The water to be treated flows by gravity into the filter segments from the centre drum. Solids catch on the inside of the filter panels mounted on the two sides of the disc segments.
- ▶ As the solids catch on the inside of the filter media impeding the flow of water through the disc, the water level inside the discs begin to rise, triggering a level sensor to start the disc to rotate and a backwash cycle begins.
- ▶ High pressure rinse water backs the solids off the filter media and into the solids collection trough. Typically the backwash requires 1-2% of the total flow and filtered water is used.

Hydrotech Discfilter is a woven media filter for fine solids removal and product recovery. The Discfilter offers a large filter area in a small footprint.

The compact design of the Discfilter makes this system a good choice for recirculation systems, effluent polishing of waste water, fine filtration of intake water or other applications where a space-saving filter with fine filter openings and larger filter area is required.

In normal operation

the Discfilter is approximately 60% submerged and the head loss across the filter media varies between 50 and 200 mm. Maximum allowable head loss with the filter in operation is 300 mm. Backwash and rotation can be continuous or controlled by an automatic level control system.

The modular filter panels consist of woven filter media, either polyester or stainless steel, which is held within a stainless steel frame. The Discfilter is as standard fabricated of 304 or 316 stainless steel. For extremely corrosive environments it can also be made of special alloys.

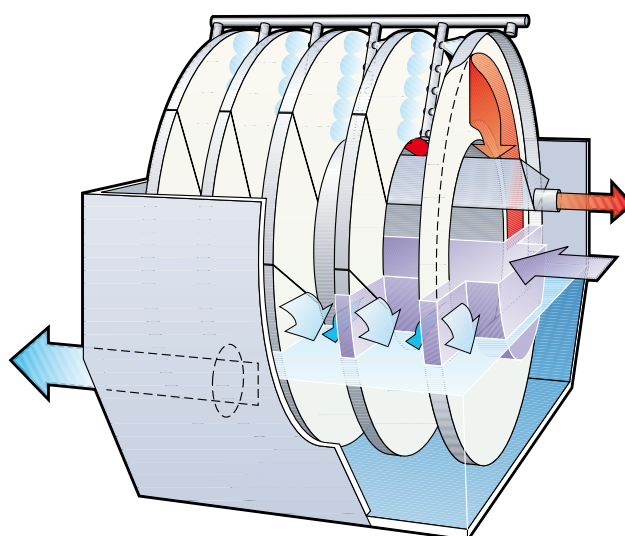

Flexibility is a key word for the Hydrotech Discfilter. The patented design of the panels means that replacement requires minimum service and downtime. If there is a change in operating or performance needs, the design also accommodates an easy switch to a filter media with a different size of opening.

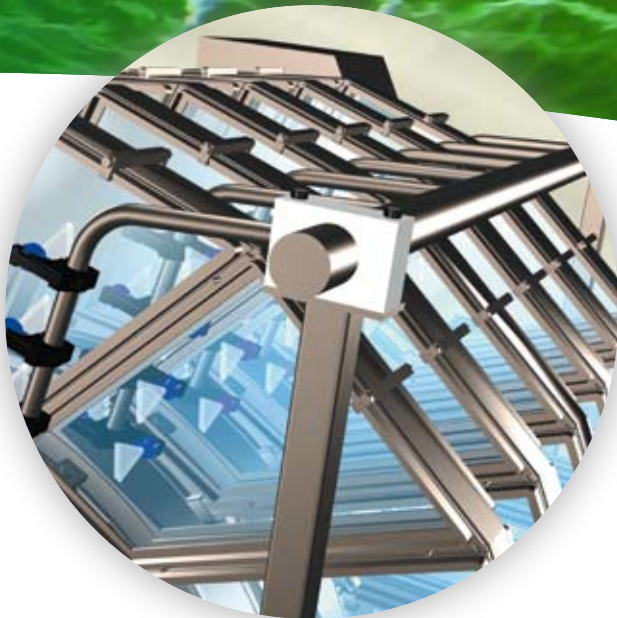

Hydrotech's moving backwash spray header ensures better cleaning with minimal water use and longer life of the filter media.

The filter panels are fastened to the disc segment by a single clamp allowing for easy replacement. This patented design results in a long service life and low maintenance costs.

There is space for up to 12 discs on the largest filter, however a filter can be installed with fewer discs and more being added as flow rate increases.

Hydrotech's patented moving backwash spray header ensures efficient cleaning of the filter media, increased life time of the filter media and 20% savings of rinse water consumption. The spray headers fold out to facilitate maintenance of the spray nozzles, that can be replaced without any tools. Filtered water is used for backwash.



The picture shows Hydrotech Discfilter type HSF2108-1F with the backwash pump installed at Hydrotech's factory (option).

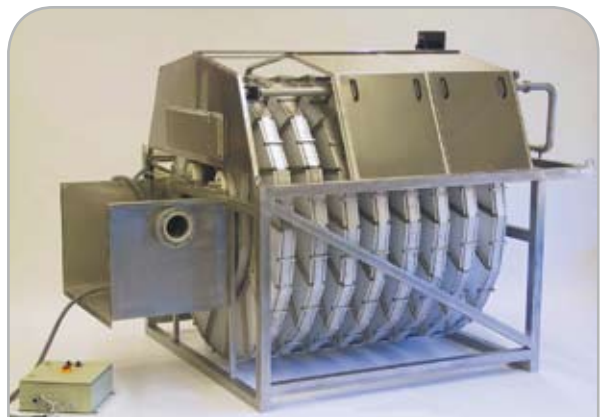

A HSF2108-2F with an optional inlet channel for installation in a concrete basin. The inlet channel serves also as emergency by-pass weir.

Type 1, tank version



- 1 Inlet
- 2 Outlet
- 3 Backwash outlet
- 4 Rinse water conn.
- 5 Backwash nozzles
- 6 Filter segments
- 7 Drive unit

Type 2, without tank – pipe inlet



Type 3, without tank – pipe inlet



The tank version of Hydrotech Discfilter is provided with an internal emergency by-pass and a level weir to maintain the water level after the filter. The versions without tanks are designed for installation in a concrete channel or basin.

Dimensions

Type 1 with tank

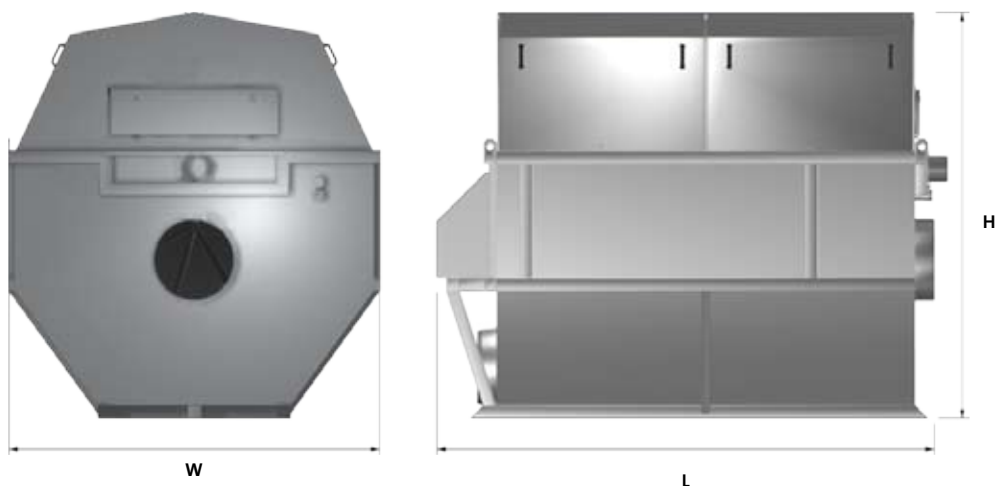

| Filter size | W mm | L mm | H mm | Nwt kg |
|-------------|------|------|------|--------|
| 1702 | 1960 | 1820 | 1985 | 950 |
| 1704 | 1960 | 2320 | 1985 | 1250 |
| 1706 | 1960 | 2820 | 1985 | 1550 |
| 1708 | 1960 | 3320 | 1985 | 1850 |
| 2102 | 2300 | 2140 | 2485 | 1800 |
| 2104 | 2300 | 2640 | 2485 | 2200 |
| 2106 | 2300 | 3140 | 2485 | 2600 |
| 2108 | 2300 | 3640 | 2485 | 3000 |
| 2110 | 2300 | 4140 | 2485 | 3400 |
| 2112 | 2300 | 4640 | 2485 | 3800 |

Type 2, without tank

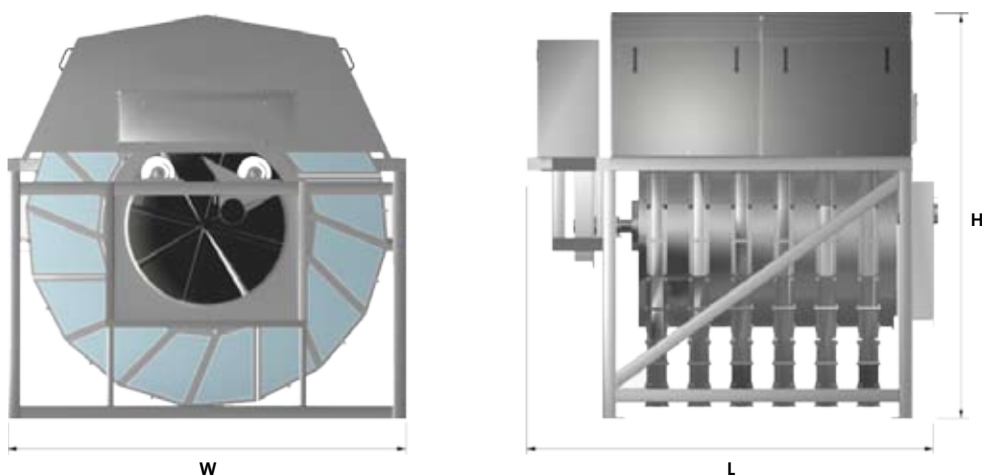

| Filter size | W mm | L mm | H mm | Nwt kg |
|-------------|------|------|------|--------|
| 1702 | 1960 | 1360 | 1920 | 1000 |
| 1704 | 1960 | 1860 | 1920 | 1200 |
| 1706 | 1960 | 2360 | 1920 | 1400 |
| 1708 | 1960 | 2860 | 1920 | 1600 |
| 2102 | 2280 | 1400 | 2400 | 1550 |
| 2104 | 2280 | 1900 | 2400 | 1850 |
| 2106 | 2280 | 2400 | 2400 | 2150 |
| 2108 | 2280 | 2900 | 2400 | 2450 |
| 2110 | 2280 | 3400 | 2400 | 2750 |
| 2112 | 2280 | 3900 | 2400 | 3050 |
| 3108 | 3200 | 3240 | 3340 | 5000 |
| 3110 | 3200 | 3740 | 3340 | 5800 |
| 3112 | 3200 | 4240 | 3340 | 6700 |

HYDROTECH

Hydrotech AB,
A Veolia Water Solutions & Technologies company

Mejselgatan 6
235 32 Vellinge
Sweden

Tel: +46-(0)40 42 95 30
Fax: +46-(0)40 42 95 31
E-mail: mailbox@hydrotech.se
www.hydrotech.se